

# Mandatory standards for exhibition structures and booths

The mandatory standards for booths and exhibition structures are designed to ensure fairness among exhibitors. All plans for island and peninsula booths or any deviations from the standards must be authorized and approved in writing by the Director of the Journées dentaires. Please send your plans by email to: [exposition@odq.qc.ca](mailto:exposition@odq.qc.ca).

## → Single aisle booth

In accordance with the standards of the International Association of Exhibitions and Events™ (IAEE), the maximum height of the back wall is 8 feet. **(A)**

The wall extending forward from the background or back wall cannot be more than 5 feet in length and 8 feet high. **(B)**

Side walls, fixtures and other exhibition items, such as tables, displays and counters, cannot extend higher than 48 inches from the floor. **(C)**

Products made to stand on the floor can exceed this limit but must be placed as close to the back wall as possible, to not obstruct the adjacent exhibitor's view.

The top of a sign at the centre of the booth must not be more than 10 feet from the floor, 3 feet from the front of the booth and 3 feet from the neighbouring booth.

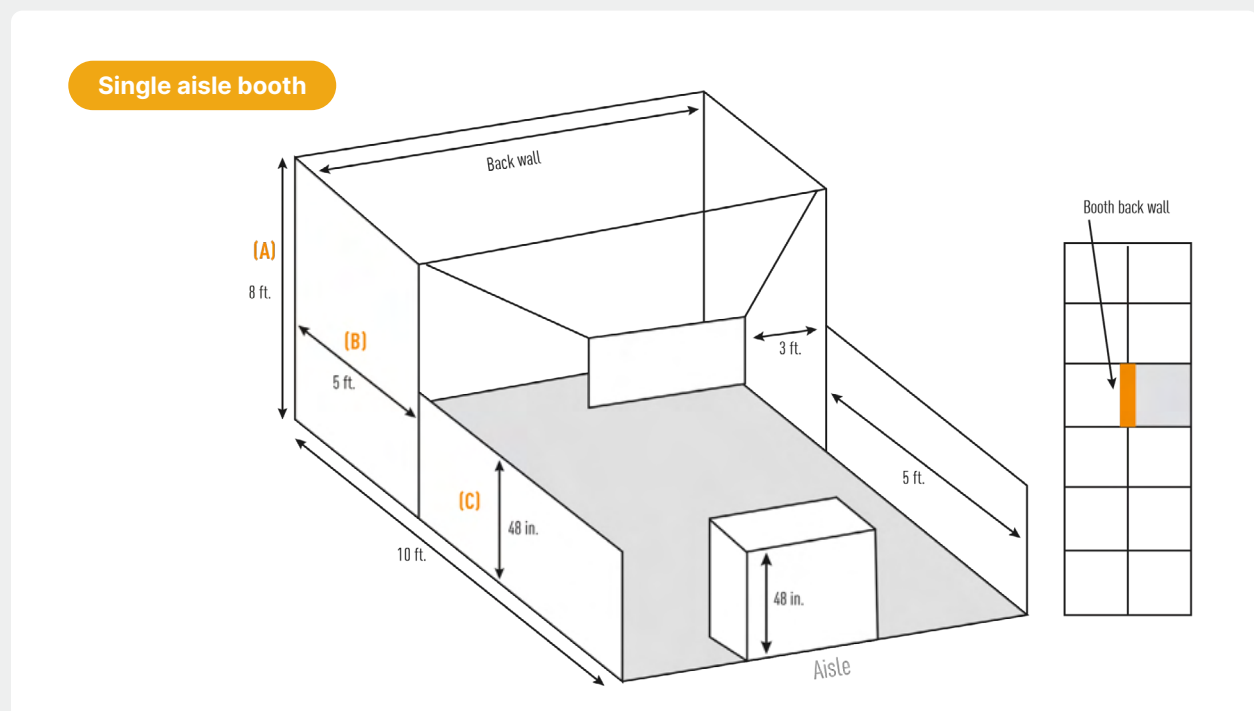

→ Two or more adjoining booths in a row

If an exhibitor has two or more adjoining exhibition spaces in a row, the back wall cannot be higher than 8 feet. The wall extending forward from the background or back wall cannot be more than 5 feet in length and 8 feet high. The common side walls must be no more than 48 inches high toward the front. Products made to stand on the floor can exceed this limit but must be placed as close to the back wall as possible, to not obstruct the adjacent exhibitor's view. The top of a sign at the centre of the booth must not be more than 10 feet from the floor, 3 feet from the front of the booth and 3 feet from the neighbouring booth.

Two or more adjoining aisle booths

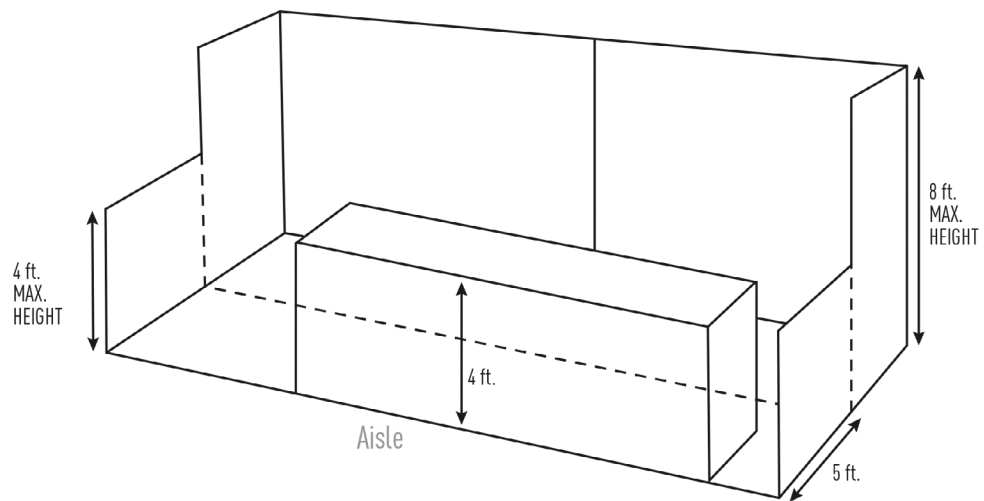

## → Peninsula (4 or more booths)

With the JDIQ Director's approval, an exhibitor can select adjoining and back-to-back booths surrounded by three aisles and adjacent to other exhibitors' booths on the fourth side.

The structures arranged into a peninsula may deviate from the mandatory standards with respect to size and location, provided the JDIQ Director approves the plans or drawings, in writing, prior to the exhibition.

Nevertheless, the **central** structure may not, under any circumstance, be more than 20 feet high and 10 feet wide, except for side walls shared with unrelated booths, which must be no more than 48 inches high toward the front. **The exhibitor will have to ensure a suitable and neutral finish of the common wall for the sake of respect for the exhibitors behind him.**

### Peninsula (4 or more booths)

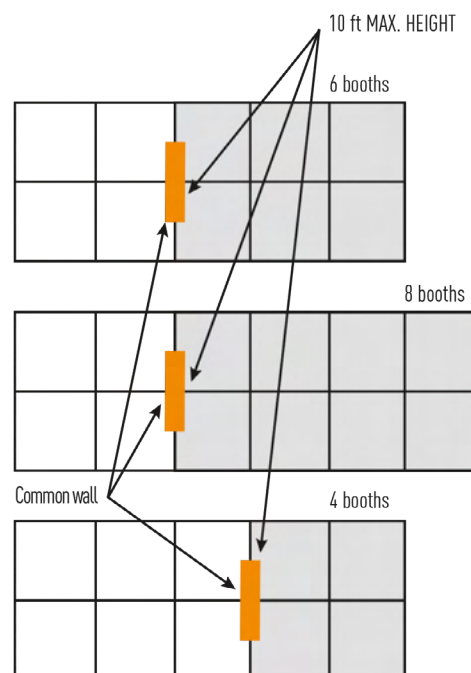
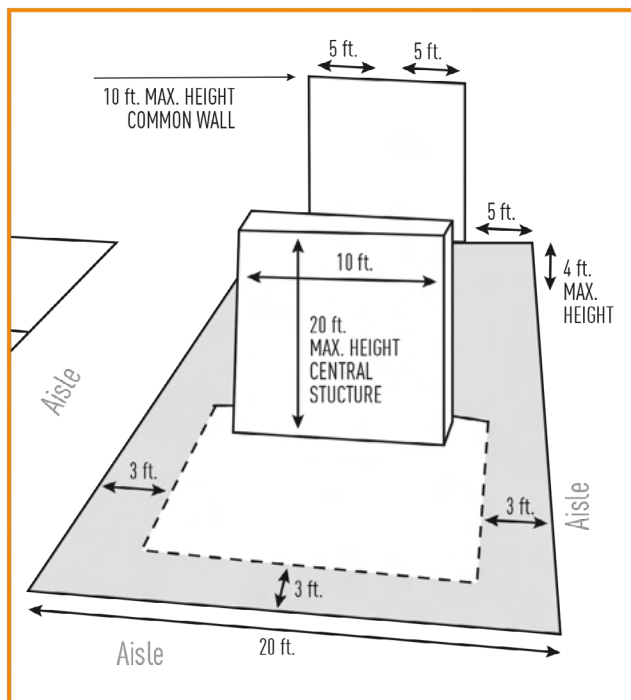

## → Island (2 or more booths)

An exhibitor can select adjoining and back-to-back booths surrounded by four aisles. The structures arranged into an island may deviate from the mandatory standards with respect to size and location, provided the JDIQ Director approves the plans or drawings, in writing, prior to the exhibition.

**Any island configuration must ensure that there is a concern for commercial fairness on the exhibition floor.** Any exemption or request for adjustment will be considered in this sense so as not to create a visual obstacle to a surrounding exhibitor.

Nevertheless, the structure may not, under any circumstance, be more than 20 feet high.

### Island (2 or more booths)

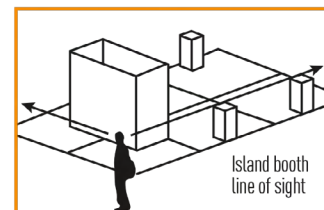
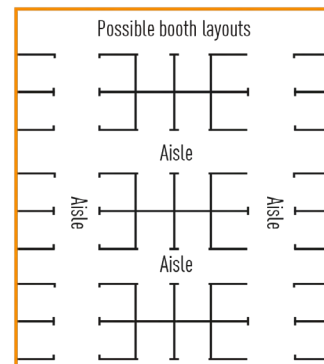
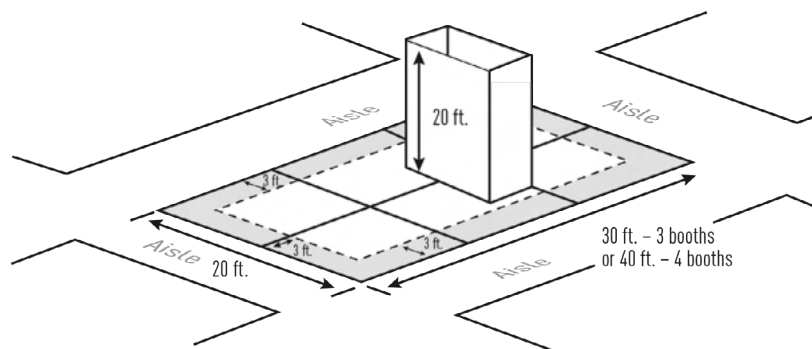

## → Aisles

Aisle space can be rented at the same price as exhibition space, provided that the exhibitor has rented an adjacent island or peninsula measuring at least 20 feet x 30 feet.

The aisle may be covered in carpet or other coating at the exhibitor expenses but cannot be used for furniture or equipment.

Rented aisle space cannot be blocked nor can traffic be impeded.

No banner or sign is authorized above the aisle unless renting the aisle.

## → Raised signs and banners within multiple booths

Signs can be placed more than 8 feet above the floor to better identify booths, provided that the following requirements are met:

- Exhibitors can display one sign for every 10 feet exhibition space.
- The top of a sign cannot be higher than 20 feet above the floor, and **the bottom cannot be lower than 8 feet above the floor**. The sign must be placed at least 3 feet from the booth's perimeter, that is, 3 feet from the neighboring booth and 3 feet from the front boundary of the booth.
- If a sign exceeds the 8-foot level and is visible from the booth on the aisle behind it, the back of the sign must be covered or finished aesthetically.
- In perimeter booths only, raised signs of all sizes can be placed beyond the 8-foot level instead of a booth back wall, provided that they are not higher than 10 feet above the ground, nor come within 3 feet from a neighboring exhibitor's booth.

